

الاسم:
الرقم:مسابقة في الفيزياء
المدة: ثلاث ساعات

*This exam is formed of four obligatory exercises in four pages numbered from 1 to 4.
The use of a non programmable calculator is allowed.*

First exercise (6.5 pts) Determination of a force of friction

In order to determine the value of the force of friction between a moving body of mass $M = 0.50$ kg and a table inclined by an angle $\alpha = 30^\circ$ with respect to the horizontal, we release the body from a point A_0 without initial velocity at the instant $t_0 = 0$ that is taken as the origin of time and we record the different positions A_i of the projection of its center of mass on the table at instants separated by a constant time interval $\tau = 60$ ms, the points A_i being held by the axis $x'x$ of motion of unit vector \vec{i}

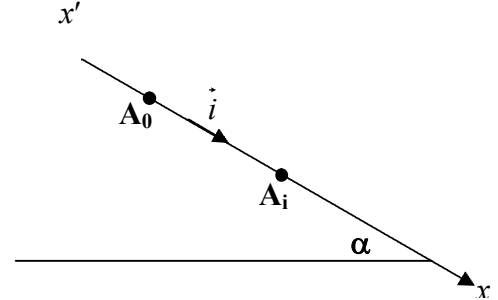

Take $g = 9.8 \text{ m/s}^2$

The recordings allow us to obtain the following table.

Instant	$t_0 = 0$	$t_1 = \tau$	$t_2 = 2\tau$	$t_3 = 3\tau$	$t_4 = 4\tau$	$t_5 = 5\tau$	$t_6 = 6\tau$
Position	A_0	A_1	A_2	A_3	A_4	A_5	A_6
Abscissa x (mm)	0	$A_0A_1 = 7.20$	$A_0A_2 = 28.9$	$A_0A_3 = 64.9$	$A_0A_4 = 115$	$A_0A_5 = 181$	$A_0A_6 = 259$
Speed V (m/s)	0	0.24		0.72		1.20	
Linear momentum P (kg.m/s)	0	0.12		0.36		0.60	

- Complete the above table by calculating, at the instants t_2 and t_4 , the speeds V_2 and V_4 and the values P_2 and P_4 of the linear momentum of the body.
- Trace the curve representing the variation of P as a function of time, using the scale :
1cm on the axis of abscissas represents 0.06 s and 1 cm on the axis of ordinates represents 0.05 kg.m/s .
- Show that the relation between the linear momentum $\vec{P} = P\vec{i}$ and the time t has the form $\vec{P} = b t\vec{i}$ where b is a constant.
- Calculate b in SI units.
- Show that the inclined table exerts on the body a force of friction \vec{f} supposed constant and parallel to the axis $x'x$.
 - Calculate the value f of \vec{f} .

Second exercise (7.5 pts)

Identification of some electric components

We intend to identify each of two electric components D_1 and D_2 , one of them being a capacitor of capacitance C , and the other a coil of inductance L and of resistance r . In order to do that, we consider a function generator (LFG) delivering an alternating sinusoidal voltage whose effective value is kept constant throughout the whole problem, an oscilloscope, a resistor of resistance $R=10\Omega$, and connecting wires.

We connect up the circuit represented in figure (1); the component D may be either D_1 or D_2 . The figures (2) and (3) show the waveforms of each of the voltages u_{AM} and u_{BM}

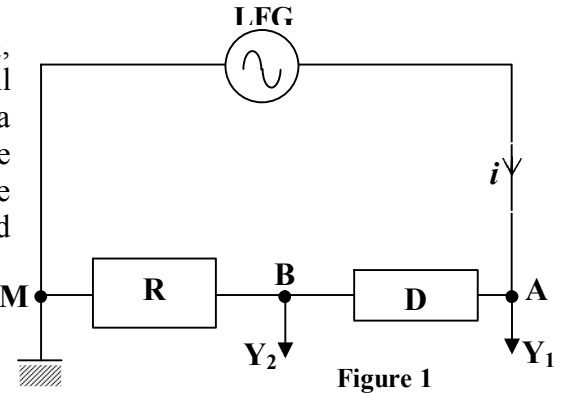

Figure 1

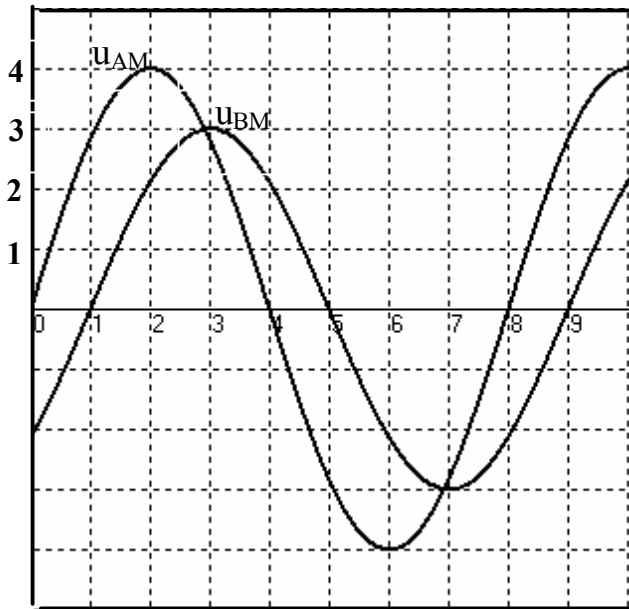

Figure 2

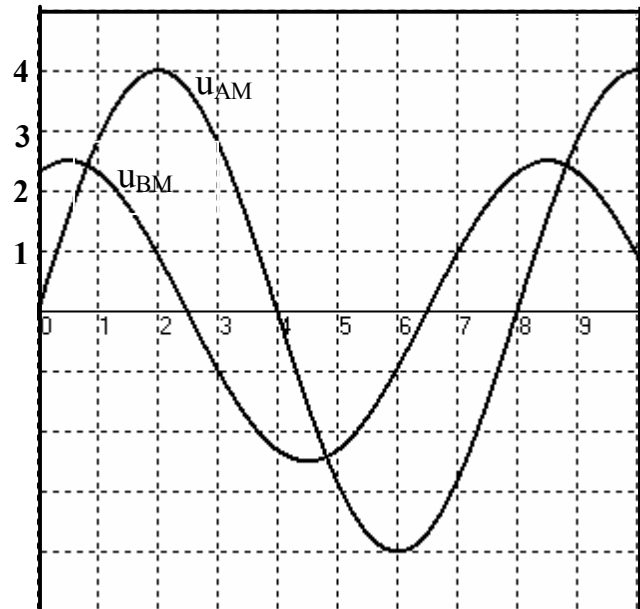

Figure 3

Given:

Horizontal sensitivity : 1ms/division

Vertical sensitivity on (Y_1) : 2 V/division

Vertical sensitivity on (Y_2) : 1V/division

A- Nature of D_1 and of D_2

The waveform of figure (2) corresponds to the case when the component D is D_1 .

D_1 is then the coil. Why?

B- Characteristics (L , r) of the coil

- Determine the period of the voltage delivered by the LFG and deduce its angular frequency ω
 - Determine the maximum values of the voltages u_{AM} and u_{BM}
 - Calculate the phase difference φ between the voltage u_{AM} and the current i carried by the circuit.
- Knowing that the current i is given by the expression $i = I_{1m} \cos \omega t$, determine:
 - the expression of each of u_{BM} , u_{AB} and u_{AM} as a function of time.
 - calculate I_{1m} .
- By applying the law of addition of voltages, determine the values of r and L by giving ωt two particular values.

C- Capacitance C of the capacitor

D_2 is now connected between A and B, the expression of the voltage u_{AB} is, in this case: $u_{AB} = \frac{I_{2m}}{C\omega} \sin \omega t$.

1. Verify that the expression of the current is: $i = I_{2m} \cos \omega t$.
2. Show that the expression of u_{AM} is : $u_{AM} = 8 \cos (\omega t - \frac{3\pi}{8})$
3. Determine the value of C.

Third exercise (6.5pts). Interference of light

Consider a source S of monochromatic light of wavelength λ and a glass plate of parallel faces of thickness e and of index $n = 1.5$.

The object of this exercise is to determine λ and e using Young's double slit apparatus.

A- Value of λ

Young's double slit apparatus is formed of two very thin and parallel slits F_1 and F_2 , separated by a distance $a = 0.15$ mm, and a screen of observation (E) placed parallel to the plane of the slits at a distance $D = 1.5$ m from this plane.

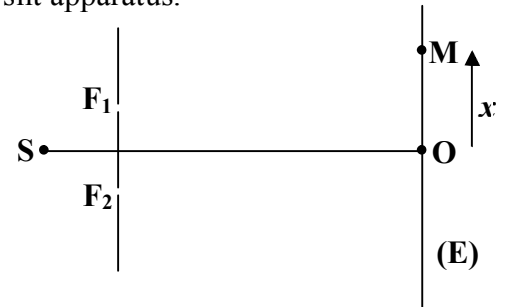

- 1) Upon illuminating F_1 by S and F_2 by another independent source S' synchronous with S, we do not observe a system of interference fringes. Why?
- 2) We illuminate F_1 and F_2 with S, placed equidistant from F_1 and F_2 we observe on (E) a system of interference fringes.
 - a) Describe this system.
 - b) At point O of the screen, equidistant from F_1 and F_2 , we observe a bright fringe. Why?
 - c) It can be shown that for a point M of (E), of abscissa $x = OM$, the optical path difference in air or in vacuum is given by $\delta = F_2M - F_1M = \frac{ax}{D}$.

Determine the expression of x_k corresponding to the k^{th} bright fringe and deduce the expression of the interfringe distance i .

- 3) We count 11 bright fringes over a distance $d = 5.6$ cm. Determine the value of λ .

B) Value of e

Now, we place the glass plate just behind the slit F_1 .

The optical path difference at point M becomes: $\delta' = \frac{ax}{D} - e(n - 1)$.

1. Show that the interfringe distance i remains the same.
2. a) The central bright fringe is no longer at O. Why?
 - b) The new position O' of the central bright fringe is the position that was originally occupied by the fifth dark fringe before introducing the plate. Determine the thickness e of the plate.

Fourth exercise (7 pts)

Studying the radionuclide $^{198}_{79}\text{Au}$

Given:

molar mass of $^{198}_{79}\text{Au}$: 198 g ;

mass of the electron: 5.50×10^{-4} u;

1 u = $931.5 \text{ MeV} / c^2 = 1.66 \times 10^{-27}$ kg ;

mass of the gold nucleus Au : 197.925 u ;

mass of the proton $m_p = 1.00728$ u ;

Avogadro's number : $6.022 \times 10^{23} \text{ mol}^{-1}$;

speed of light in vacuum $c = 3 \times 10^8$ m/s;

1 eV = 1.6×10^{-19} J;

mass of the mercury nucleus Hg : 197.923 u;

mass of the neutron $m_n = 1.00866$ u.

A- Comparison between the density of the gold nucleus and that of the gold atom

1) a) Calculate the mass of the gold atom $^{198}_{79}\text{Au}$.

b) Compare the mass of the gold atom $^{198}_{79}\text{Au}$ with that of its nucleus.

2) The average radius of the gold atom is $r = 16 \times 10^{-11}$ m. The average radius of a nucleon is $r_0 = 12 \times 10^{-16}$ m. Compare the density of the gold atom with that of its nucleus. Give a conclusion about the distribution of mass in the atom.

B- Stability of the gold nucleus

1. a) Give the constituents of the nucleus $^{198}_{79}\text{Au}$.

b) If the gold nucleus $^{198}_{79}\text{Au}$ is broken into its constituting nucleons, show that the sum of the masses of the nucleons taken separately at rest is greater than the mass of the nucleus taken at rest.

Due to what is this increase in the mass?

2. Knowing that a nucleus is considered stable when its binding energy per nucleon is larger or equal to 8 MeV, give a conclusion about the stability of the nucleus $^{198}_{79}\text{Au}$.

C- Studying the disintegration of the gold nucleus $^{198}_{79}\text{Au}$

When the gold nucleus $^{198}_{79}\text{Au}$, at rest, disintegrates it gives a daughter nucleus (mercury nucleus ^A_ZHg) of negligible speed. We were able to detect the emission of a γ photon of energy 0.412 MeV and a β^- particle of kinetic energy 0.824 MeV.

1. Write the equation of this disintegration reaction and, specifying the laws used, determine A and Z .

2. a) Specify the physical nature of the γ radiation.

b) Due to what is the emission of this γ radiation ?

3. a) Show, by applying the law of conservation of total energy, the existence of a new particle accompanying the emission of β^- .

b) Give the name of this particle.

c) Deduce its energy in MeV.

4. Calculate the speed V of the relativistic particle β^- knowing that its kinetic energy is given by:

$$\text{K.E (relativistic)} = mc^2(\gamma - 1) \quad \text{with} \quad \frac{1}{\gamma} = \sqrt{1 - \frac{V^2}{c^2}}$$

First exercise :

1) $V_2 = \frac{A_1 A_3}{2\tau}$ (1/4pt.) $\Rightarrow V_2 = \frac{57.7}{0.12} = 481 \text{ mm/s}$ (1/4 pt.)

$V_4 = \frac{A_3 A_5}{2\tau}$ (1/4 pt.) $\Rightarrow V_4 = \frac{116.1}{0.12} = 967 \text{ mm/s}$ (1/4 pt.)

$P_2 = MV_2$ (1/4 pt.)

$P_2 = 0.24 \text{ kgm/s}$. (1/4 pt.)

$P_4 = MV_4$; $P_4 = 0.48 \text{ kg.m/s}$. (1/4 pt.)

2) Trace the curve (1pt.)

3) The curve is a straight line passing through the origin ; $P = b t$

(1/4pt.)

But $\vec{P} = m\vec{V}$ and $\vec{V} = V\vec{i}$; $\vec{P} = P\vec{i}$; thus $\vec{P} = bt\vec{i}$. (1/4pt.)

4) $b = \frac{P_5 - P_1}{4\tau} = 2 \text{ kgm/s}^2$. (1/2 pt.)

5) a) $\frac{d\vec{P}}{dt} = b\vec{i} = 2\vec{i}$ (1/4pt)

Newton's second law, applied on the moving body, is written as: $\frac{d\vec{P}}{dt} = \Sigma \vec{F}$. (1/4 pt.)

If there are no forces of friction , we have:

$\Sigma \vec{F} = m\vec{g} + \vec{N}$; \vec{N} being the normal reaction exerted by the table on the body. $\Sigma \vec{F} = mg\sin\alpha \vec{i} - mg\cos\alpha \vec{j} + N\vec{j}$

The motion takes place along \vec{x} , we have $-mg\cos\alpha \vec{j} + N\vec{j} = \vec{0}$; thus $\Sigma \vec{F} = mg\sin\alpha \vec{i} = 0.5 \times 9.8 \times 0.5 \vec{i} = 2.45 \vec{i}$.

In this case: $\frac{d\vec{P}}{dt}$ is not equal to $\Sigma \vec{F}$.

The force of friction \vec{f} must exist. (11/4pt.)

b) $\Sigma \vec{F} = (mg\sin\alpha - f) \vec{i} = \frac{d\vec{P}}{dt} = 2\vec{i}$.

Thus : $mg\sin\alpha - f = 2 \Rightarrow f = 2.45 - 2 = 0.45 \text{ N}$. (1 pt.)

Second exercise :

A- Figure (2) correspond to the case of the coil since u_{AM} is leading u_{BM} which represents the image of the current **(1/2 pt)**

B) 1) a) $T=8\text{div}\times 1\text{ms}/\text{div}=8\text{ms}=8\times 10^{-3}\text{s}$. **(1/4pt)**

$$\omega = 2\pi / T ; \quad \omega = 785\text{rad/s} \quad \textbf{(1/4 pt)}$$

b) $(U_{AM})_{\max} = 4 \text{ div}\times 2 \text{ V}/\text{div} = 8 \text{ V}$ **(1/4pt)**

$$(U_{BM})_{\max} = 3 \text{ div}\times 1 \text{ V}/\text{div} = 3 \text{ V} \quad \textbf{(1/4pt)}$$

$$\textbf{c)} \quad \varphi = \frac{2\pi \times 1\text{div}}{8\text{div}} = \frac{\pi}{4} \text{rad} \quad \textbf{(1/4pt)}$$

2) a) $u_{BM}=Ri=R I_{1m} \cos \omega t$ **(1/4pt)**

$$u_{AB}=ri+Ldi/dt = r I_{1m} \cos \omega t -L \omega I_{1m} \sin \omega t \quad \textbf{(1/2pt)}$$

$$u_{AM} = 8\cos(\omega t + \frac{\pi}{4}) \quad \textbf{(1/4pt)}$$

$$\textbf{b) } R I_{1m} = 3V \Rightarrow I_{1m} = 0.3A \quad \textbf{(1/4pt)}$$

$$\textbf{3) } 8\cos(\omega t + \frac{\pi}{4}) = (r+R) I_{1m} \cos \omega t - L \omega I_{1m} \sin \omega t$$

$$\text{for } \omega t = 0 \text{ we have: } 8\cos\frac{\pi}{4} = (r+R) I_{1m} \Rightarrow r = 8.85\Omega . \quad \textbf{(3/4pt)}$$

$$\text{for } \omega t = \frac{\pi}{2} \text{ we have : } -8\sin\frac{\pi}{4} = -L \omega I_{1m} \Rightarrow L = 24 \text{ mH}. \quad \textbf{(3/4pt)}$$

C-1) $i = dq/dt = Cdu_{AB}/dt = I_{2m} \cos \omega t$ **(1/2pt)**

$$\textbf{2) } (U_{AM})_{\max} = 8V ; u_{AM} \text{ lags } i \text{ by } \beta . \quad \beta = \frac{1.5 \times 2\pi}{8} = \frac{3\pi}{8} \text{rad}.$$

$$\Rightarrow u_{AM} = 8 \cos(\omega t - \frac{3\pi}{8}) \quad \textbf{(11/4pt)}$$

$$\textbf{3) } 8 \cos(\omega t - \frac{3\pi}{8}) = \frac{I_{2m}}{C\omega} \sin \omega t + R I_{2m} \cos \omega t.$$

$$\text{for } \omega t = \frac{\pi}{2} \text{ we have : } 8\sin\frac{3\pi}{8} = \frac{I_{2m}}{C\omega}$$

$$\text{with } R I_{2m} = 2.5 \text{ V we have : } I_{2m} = 0.25 \text{ A. } \Rightarrow C = 43 \mu\text{F}. \quad \textbf{(11/4pt)}.$$

Third exercise :

- **A-1)** because the two sources are not coherent **(1/2 pt)**

2)a) We observe straight fringes that are:

- Rectilinear **(1/4 pt)**
- Parallel to the slits **(1/4 pt)**
- equidistant **(1/4pt)**

alternately bright and dark **(1/4pt)**

b) Light waves reach o in phase (or their optical path difference at O is zero). **(1/2 pt)**

c) The abscissa of a bright fringe satisfies the relation : $\delta = \frac{ax}{D} = K\lambda$

(K is a whole number) \Rightarrow the abscissa of the k^{th} bright fringe is :

$$x_K = K \frac{\lambda D}{a} \text{ (1/2 pt)}$$

$$i = (K+1) \frac{\lambda D}{a} - K \frac{\lambda D}{a} = \frac{\lambda D}{a} \text{ (3/4pt.)}$$

$$3) d = 10 i = 10 \frac{\lambda D}{a} \text{ (1/2pt.)} \Rightarrow \lambda = \frac{ad}{10D} \text{ (1/4pt.)}$$

$$\Rightarrow \lambda = 0.56 \mu\text{m} \text{ (1/2pt.)}$$

$$\mathbf{B) 1) } \delta' = \delta - e(n-1) = \frac{ax}{D} - e(n-1) = K' \lambda \text{ (1/2pt)}$$

Bright fringe $\Rightarrow \delta' = K' \lambda$ **(1/4 pt)**

$$\Rightarrow x_{K'} = K' \frac{\lambda D}{a} + \frac{e(n-1)D}{a}$$

$$\Rightarrow \Rightarrow i' = (K+1) \frac{\lambda D}{a} - K \frac{\lambda D}{a} = \frac{\lambda D}{a} = i \text{ (the same) (1/4 pt)}$$

$$2) \mathbf{a) } \delta' = \frac{ax}{D} - e(n-1) \text{ for } x = 0 \Rightarrow \delta' = - e(n-1) \neq 0 \text{ (1/4pt)}$$

\Rightarrow the central bright fringe is not at O **(1/4pt.)**

b) The abscissa x_0 of the central bright fringe is such that $\delta' = 0 \Rightarrow x_0 = 9 \frac{i}{2}$ **(1/2 pt)**

$$\delta' = 0 \Rightarrow x_0 = \frac{e(n-1)D}{a} \Rightarrow e = 9\lambda \Rightarrow e = 5.04 \mu\text{m} \text{ (1/2pt)}$$

Fourth exercise:

A-1) a) $m_{\text{atom}} = \frac{198}{6.022 \times 10^{23}} = 32.879 \times 10^{-23} \text{ g}$ (1/4 pt)

b) $m_{\text{nucleus}} = 197.925 \times 1.66 \times 10^{-24} \text{ g} = 32.855 \cdot 10^{-23} \text{ g} \Rightarrow m_{\text{atom}} \approx m_{\text{nucleus}}$

(1/4pt)

2) $\rho_{\text{atom}} = \frac{m_{\text{atom}}}{V_{\text{atom}}} = \frac{m_{\text{atom}}}{\frac{4}{3}\pi r^3} = 19.16 \times 10^3 \text{ Kg/m}^3$ (1/2pt)

$\rho_{\text{nucleus}} = \frac{m_{\text{nucleus}}}{V_{\text{nucleus}}} = \frac{m_{\text{nucleus}}}{A \times \frac{4}{3}\pi r_0^3} = 2.3 \times 10^{17} \text{ Kg/m}^3$. (1/2pt)

$\rho_{\text{nucleus}} = 10^{13} \rho_{\text{atom}}$ (1/4 pt)

The matter forming the atom is concentrated in the nucleus. (1/4pt)

B-1) a) 79 protons and 119 neutrons (1/4 pt)

b) $79 m_p + 119 m_n = 199.605 \text{ u}$ (1/4pt)

$m_{\text{nucleus}} = 197.925 \text{ u} < 199.605 \text{ u}$. (1/4 pt)

the binding energy. or the energy transformed into mass (1/4 pt)

2) $E_1 = \Delta m \times c^2$ (1/4 pt)

$\Delta m = Zm_p + (A-Z)m_n - m_{\text{nucleus}} = 1.68066 \text{ u}$ (1/4pt)

$E_1 = 1565.535 \text{ MeV}$ (1/4 pt) $\Rightarrow E_1/A = 7.9 \text{ MeV}$ (1/4 pt)

$E_1/A < 8 \text{ MeV}$ (1/4 pt) \Rightarrow The ${}^{198}_{79}\text{Au}$ nucleus is unstable. (1/4 pt)

C- 1) ${}^{198}_{79}\text{Au} \rightarrow {}^{198}_{80}\text{Hg} + {}^0_{-1}e + \gamma$ (1/2pt)

The laws of conservation of mass number A and charge number Z. (1/4 pt)

2) a) The γ radiation is an electromagnetic wave. (1/4 pt)

b) The daughter nucleus Hg being in an excited state, it undergoes a downward transition giving the γ radiations. (1/4pt)

3) a) $E_{\text{total before}} = E_{\text{total after}}$

$\sum (\text{K.E} + E_{\text{mass}})_{\text{before}} = \sum (\text{K.E} + E_{\text{mass}})_{\text{after}}$

$(m_{\text{Au}}c^2 + 0) = (m_{\text{Hg}}c^2 + 0) + (m_{e^-}c^2 + \text{K.E}_{e^-}) + E(\gamma)$

$[m_{\text{Au}} - (m_{\text{Hg}} + m_{e^-})]c^2 = \text{K.E}_{e^-} + E(\gamma) \Rightarrow 1.351 \text{ MeV} > 1.236 \text{ MeV} \Rightarrow$ Thus the need to assume the production of a new particle. (1/2 pt)

b- Antineutrino (1/4 pt)

c) $E = 1.351 - 1.236 = 0.115 \text{ MeV}$ (1/4 pt)

4) $E_{\text{mass}} = mc^2 = 0.00055 \times 931.5 = 0.512 \text{ MeV}$.

$Ec = (\gamma - 1) m c^2 \Rightarrow 0824 = (\gamma - 1) 0.512$

$\Rightarrow \gamma = 2.6 \Rightarrow V = 2.7 \times 10^8 \text{ m/s}$ (1/2 pt)