

This exam is formed of four exercises in 4 pages

The use of non-programmable calculators is recommended

First exercise (7 pts)

Mechanical oscillations

Consider a pierced disk (D), of mass $M = 59 \text{ g}$, that may rotate, without friction, about a horizontal axis (Δ) perpendicular to its plane through O, O being the center of the homogeneous disk before being pierced. The center of mass G of the pierced disk (D) is at a distance a from O ($a = OG$). The object of this exercise is to determine the value of a and that of the moment of inertia I of the disk (D) with respect to the axis (Δ).

The horizontal plane through O is taken as a gravitational potential energy reference.

Take : $\sin\theta = \theta$ and $\cos\theta = 1 - \frac{\theta^2}{2}$ for small angles, θ being in radian ; $g = 10 \text{ m/s}^2$; $\pi^2 = 10$

I – Compound pendulum

The disk (D) is at rest in its position of stable equilibrium. We shift it by a small angle θ_m and then we release it without velocity at the instant $t_0 = 0$.

The compound pendulum thus formed oscillates without friction on both sides of its equilibrium position with a proper period T_1 (Fig.1).

At an instant t , the position of (D) is defined by its angular abscissa θ that OG makes with the vertical OY, and its angular velocity is $\theta' = \frac{d\theta}{dt}$.

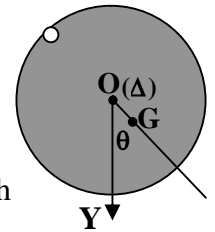

Fig.1

- 1) Write down, at the instant t , the expression of the kinetic energy of the pendulum in terms of I and θ' .
- 2) Show that the expression of the gravitational potential energy of the system (pendulum, Earth) is $P.E_g = -M g a \cos\theta$.
- 3) Write down the expression of the mechanical energy of the system (pendulum, Earth) in terms of M, g, a, θ, θ' and I.
- 4) Derive the second order differential equation that governs the motion of (D).
- 5) Deduce that the expression of the proper period T_1 , for small oscillations, can be written as :

$$T_1 = 2\pi \sqrt{\frac{I}{Mga}}$$

II- Oscillating system

The disk (D) is now welded from its center to two identical and horizontal torsion wires OA and OB ($OA = OB$) (Fig.2). The extremities A and B are fixed.

The torsion constant of each of the wires is $C = 2.8 \times 10^{-3} \text{ m.N}$.

Starting from its stable equilibrium position, we turn (D) by a small angle θ_m around AB, confounded with (Δ) ; the two wires are twisted, in the same direction, by the same angle θ_m .

Released without velocity at the instant $t_0 = 0$, (D) starts to oscillate around the horizontal axis AB. At an instant t , the position of (D) is defined by its angular abscissa θ that OG makes with the vertical OY, (each wire is then twisted by θ) and its angular velocity is θ' . The oscillating system performs then a periodic motion of proper period T_2 .

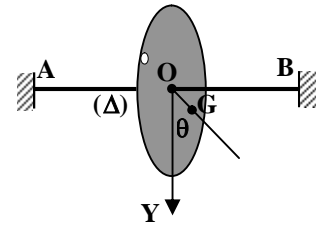

Fig.2

- 1) a) Write down, at an instant t , the expression of the torsion potential energy of the wires in terms of C and θ .
 - b) Give then the expression of the potential energy of the system (oscillating system, Earth) in terms of C , θ , M , g and a .
 - c) Deduce the expression of the mechanical energy of the system (oscillating system, Earth).
- 2) Determine the expression of the proper period T_2 in terms of I , M , a , g and C .

III- Values of I and a

Knowing that the measured values of T_1 and T_2 are $T_1 = 4.77\text{s}$ and $T_2 = 2.45\text{s}$, use the results of parts **I** and **II**, deduce the values of I and a .

Second exercise (7pts) Mode of charging a capacitor

A metallic rod MN , of length $\ell = 1\text{m}$ and of negligible resistance, may slide without friction along two long parallel and horizontal rectilinear rails AA' and EE' of negligible resistance. During its displacement, the rod remains perpendicular to the rails. An electric component (D) and a resistor of resistance $R = 100 \Omega$ are connected to the rails with connecting wires. The whole set-up thus described is placed in a uniform vertically upwards magnetic field \vec{B} of magnitude $B = 0.8 \text{ T}$ (adjacent figure).

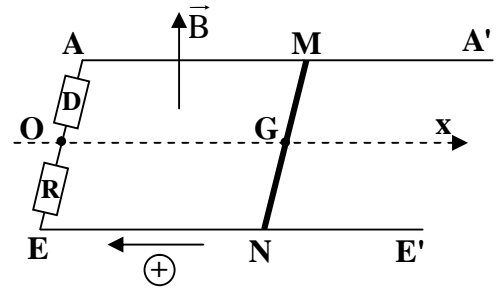

At the instant $t_0 = 0$, the center of mass G of the rod is at O . A convenient apparatus causes the rod to move in a uniform translational motion from left to right with a speed $v = 0.5 \text{ m/s}$.

At an instant t , the position of G is defined by its abscissa $x = \overline{OG}$ on the axis $x'x$.

- 1) Find, at the instant t , the expression of the magnetic flux that crosses the surface $AMNE$ in terms of B , ℓ and x taking into consideration the positive direction indicated on the figure.
 - 2) a) Explain the existence of an induced e.m.f e across the ends M and N of the rod and show that its value is 0.4 V .
 - b) At the instant t , an induced current i passes in the circuit. Determine its direction.
 - c) Draw a diagram showing the equivalent generator between M and N and specify its positive terminal.
- 3) The component (D) is a capacitor of capacitance $C = 10^{-2} \text{ F}$. During the displacement of the rod, (D) undergoes the phenomenon of electric charging.
 - a) Derive the differential equation that describes the variations of $u_C = u_{OA}$ as a function of time.
 - b) i) Calculate the value of the time constant of the circuit thus formed.
 - ii) After how long would the capacitor be practically charged completely?
 - c) At the end of charging, the voltage across the capacitor is U and its charge is Q . Calculate U and Q .
 - d) Determine the values of i at the instants $t_0 = 0$ and $t_1 = 6 \text{ s}$.
 - e) At the instant $t_1 = 6 \text{ s}$, the rod is stopped. The circuit carries again a current.
 - i) Due to what is this current?
 - ii) Specify the duration of the passage of this current.

Third exercise (7 pts) The two aspects of light

A – Diffraction

A source of monochromatic radiation of wavelength λ in air illuminates under normal incidence a horizontal slit F of adjustable width a cut in an opaque screen (P). A screen of observation (E) is placed parallel to (P) at a distance $D = 5$ m (Fig.1).

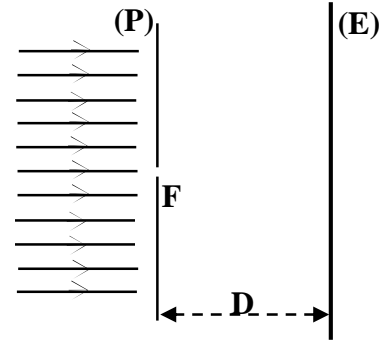

Fig. 1

- 1) For $\lambda = 0.5 \mu\text{m}$, show on a diagram the shape of the luminous beam emerging from the slit in each of the two following cases :
 - width of the slit $a = 2$ cm.
 - width of the slit $a = 0.4$ mm.
- 2) The width of the slit is now kept at 0.4 mm and the radiation used belongs to the visible spectrum. (wavelength of the visible spectrum : $0.4 \mu\text{m} \leq \lambda \leq 0.8 \mu\text{m}$)
 - a) Write , in this case, the expression giving the angular width of the central bright fringe in terms of λ and a .
 - b) Show that the linear width of this central fringe is given by : $L = \frac{2D\lambda}{a}$.
 - c) Calculate the linear widths L_{red} and L_{violet} , when using successively a red radiation ($\lambda_{\text{red}} = 0.8 \mu\text{m}$) and a violet radiation ($\lambda_{\text{violet}} = 0.4 \mu\text{m}$).
 - d) We illuminate the slit with white light. We observe over the linear width L_{violet} white light. Justify.

B – Photoelectric effect

A source of wavelength $\lambda = 0.5 \mu\text{m}$ in air illuminates separately two metallic plates, one made of cesium and the other of zinc.

The table below gives, in eV, the values of the extraction energy W_0 (work function) for some metals.

Metal	Cesium	Rubidium	Potassium	Sodium	Zinc
W_0 (eV)	1.89	2.13	2.15	2.27	4.31

Given : $h = 6.63 \times 10^{-34}$ J.s ; $1 \text{ eV} = 1.6 \times 10^{-19}$ J ; $c = 3 \times 10^8$ m/s.

- 1) Calculate, in J and in eV, the energy of an incident photon.
- 2) For what metal would photoelectric emission take place? Justify.
- 3) Calculate in eV the maximum kinetic energy of an emitted electron.
- 4) The cesium plate receives a monochromatic luminous beam of wavelength in air $\lambda = 0.5 \mu\text{m}$, of power $P = 3978 \times 10^{-4}$ W. The number of electrons emitted per second is then $n = 10^{16}$.
 - a) Calculate the number N of photons received by the plate in one second.
 - b) The quantum efficiency r of the plate is the ratio of the number of the electrons emitted per second to the number of photons received by the plate during the same time. Calculate r .

C - Duality wave-particle

The wave theory of light is used to interpret the phenomenon of diffraction. This theory is not able to interpret the photoelectric effect. Why?

Fourth exercise (6 1/2 pts) **Role of a coil in a circuit**

Consider the circuit represented in figure 1 where:

(G) is a DC generator of e.m.f $E = 9 \text{ V}$ and of negligible internal resistance ;

(D₁) is a resistor of resistance $R_1 = 90 \Omega$;

(D₂) is a resistor of resistance R_2 ;

(B) is a coil of inductance $L = 1 \text{ H}$ and of negligible resistance ;

(K) is a double switch.

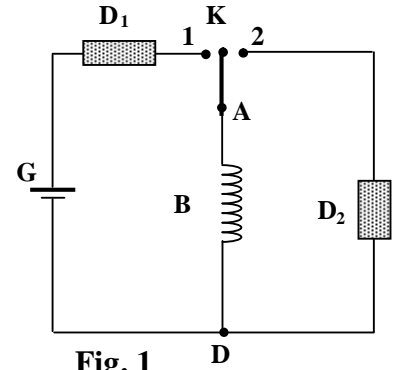

Fig. 1

I - Growth of the current in the component (R₁, L)

We place the switch in position 1 at an instant taken as an origin of time ($t_0 = 0$).

At an instant t , the circuit carries a current i_1 .

1) Derive the differential equation in i_1 .

2) Verify that $i_1 = \frac{E}{R_1} (1 - e^{-\frac{R_1}{L}t})$ is a solution of the preceding differential equation.

3) a) Find, in the steady state, the expression of the current I_0 in terms of E and R_1 .

b) Calculate I_0 .

II – Decay of the current in the component (R₂, L) and illumination of a lamp

A - Decay of the current in the component (R₂, L)

At an instant chosen as a new origin of time ($t_0 = 0$), we turn the switch K to position 2.

At an instant t , the circuit carries thus a current i_2 .

1) Determine the direction of this current .

2) Derive the differential equation in i_2 .

3) The solution of this differential equation is of the form $i_2 = \alpha e^{-\beta t}$.

Show that $\alpha = I_0$ and $\beta = \frac{R_2}{L}$.

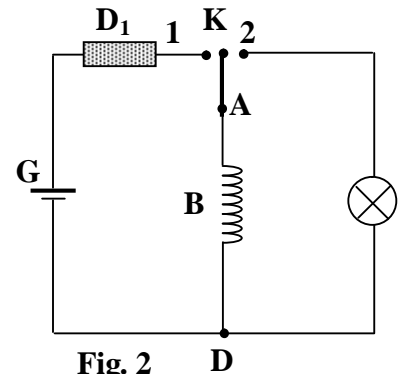

Fig. 2

B – Duration of illumination of a lamp

The resistor D₂ is a lamp of resistance $R_2 = 400 \Omega$ (fig. 2).

This lamp gives light as long as the current it carries is not less than 20 mA.

1) Show that the lamp gives light at the instant when the circuit is closed.

2) Determine the duration of the illumination of the lamp.

Solution

First exercise : (7 pts)

I-

- 1) K.E = $\frac{1}{2} I(\theta')^2$. (1/4 pt)
- 2) P.E = - Mgh; $h = a \cos \theta$ (Figure) \Rightarrow P.E = - Mga $\cos \theta$. (3/4 pt)
- 3) M.E = K.E + P.E = $\frac{1}{2} I(\theta')^2 - Mga \cos \theta$. (1/4 pt)
- 4) Friction is neglected $\Rightarrow \frac{dE_m}{dt} = 0 = I\theta''\theta' + Mga\theta'\sin\theta$.
For small angles, $\sin\theta = \theta$ (rad) $\Rightarrow I\theta''\theta' + Mga\theta'\theta = 0$
 $\Rightarrow I\theta'' + Mga\theta = 0 \Rightarrow \theta'' + \frac{Mga}{I}\theta = 0$. (3/4 pt)
- 5) The motion is angular sinusoidal of angular frequency $\omega_1 = \sqrt{\frac{Mga}{I}}$;
The period of the motion is $T_1 = \frac{2\pi}{\omega_1} = 2\pi\sqrt{\frac{I}{Mga}}$. (1/2pt)

II-

- 1) a) P.E_{torsion} = $\frac{1}{2} C\theta^2 + \frac{1}{2} C\theta^2 = C\theta^2$ (1/2pt)
b) P.E = P.E_g + P.E_{torsion} = - Mga $\cos \theta + C\theta^2$. (1/2pt)
c) M.E = $\frac{1}{2} I(\theta')^2 - Mga \cos \theta + C\theta^2$. (1/2pt)
- 2) $\frac{dM.E}{dt} = 0 = I\theta''\theta' + Mga\theta'\sin\theta + 2C\theta\theta' \Rightarrow$
 $I\theta'' + Mga\theta + 2C\theta = 0 \Rightarrow \theta'' + \left[\frac{Mga + 2C}{I} \right]\theta = 0$. (1 pt)
 $T_2 = \frac{2\pi}{\omega_2} = 2\pi\sqrt{\frac{I}{Mga + 2C}}$. (1/2 pt)

III- $a = 3.4 \text{ mm}$; $I = 1.14 \times 10^{-3} \text{ kgm}^2$. (1 1/2 pt)

Second exercise : (7pts)

1) $\Phi = B S \cos 180 = - BS = - B\ell x$ **(1/2 pt)**

2) a) Φ varies because S varies $\Rightarrow e = - \frac{d\phi}{dt}$ exists. **(1/2 pt)**

$$e = B\ell \frac{dx}{dt} = B\ell v = 0.8 \times 1 \times 0.5 = 0.4 \text{ V.} \quad \text{(3/4 pt)}$$

b) The induced current opposes, by its electromagnetic effect, the cause that produces it. The Laplace force then opposes the direction of displacement of the rod ; The induced current then passes through the rod from point M to point N. **(1/2 pt)**

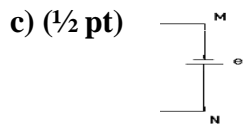

3) a) $e = Ri + u_C = RC \frac{du_C}{dt} + u_C$ **(1/2 pt)**

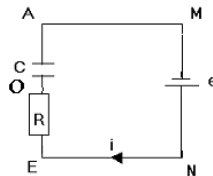

b) i) $\tau = RC = 100 \times 10^{-2} = 1 \text{ s.} \quad \text{(1/2 pt)}$

ii) The complete charge is practically attained at $5 \tau = 5 \text{ s.} \quad \text{(1/2 pt)}$

c) $U = e = 0.4 \text{ V.} \quad Q = CU = 10^{-2} \times 0.4 = 0.004 \text{ C.} \quad \text{(1 pt)}$

d) $e = Ri + u_C$. For $t_0 = 0$, $u_C = 0 \Rightarrow e = RI_0 \Rightarrow I_0 = \frac{0.4}{100} = 4 \text{ mA}$

For $t = 6 \text{ s}$, the capacitor is charged completely $\Rightarrow u_C = e \Rightarrow i = 0. \quad \text{(1 pt)}$

e) i) Is a result of discharging of the capacitor through the resistor **(1/4 pt)**

ii) The duration of the passage of the current of discharging is $5 \tau = 5 RC = 5 \text{ s} \quad \text{(1/2 pt)}$

Third exercise : (7 pts)

A-1) (½ pt)

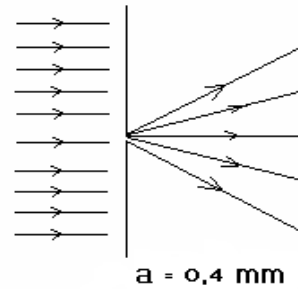
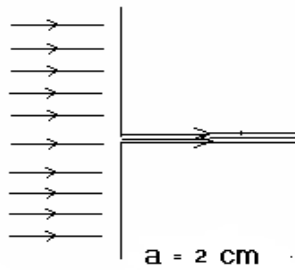

2) a) $\alpha = \frac{2\lambda}{a}$. (½ pt)

b) $\alpha = \frac{2\lambda}{a} = \frac{L}{D}$ (Figure) $\Rightarrow L = \frac{2D\lambda}{a}$. (¾ pt)

c) $L_{\text{Red}} = \frac{2D\lambda_{\text{Red}}}{a} = 2 \text{ cm}$; $\lambda_{\text{Red}} = 2 \lambda_{\text{Violet}}$

$\Rightarrow L_{\text{Red}} = 2 L_{\text{Violet}} \Rightarrow L_{\text{Violet}} = 1 \text{ cm}$ (½ pt)

d) The linear width L of the central fringe is: $1 \text{ cm} \leq L \leq 2 \text{ cm}$.

All the central bright fringes superposed within 1 cm:

We obtain white fringe. (¾ pt)

B-1) $E = h\nu = \frac{hc}{\lambda} = \frac{6.63 \times 10^{-34} \times 3 \times 10^8}{0.5 \times 10^{-6}} = 39.78 \times 10^{-20} \text{ J}$

$E = \frac{39.78 \times 10^{-20}}{1.6 \times 10^{-19}} \text{ eV} = 2.49 \text{ eV}$. (1¼ pt)

2) There is photoelectric emission from cesium because : $2.49 > 1.89$

$2.49 < 4.31 \Rightarrow$ there is no photoelectric emission from zinc. (½ pt)

3) $E = W_0 + K.E_{\text{max}} \Rightarrow K.E_{\text{max}} = 2.49 - 1.89 = 0.6 \text{ eV}$. (¾ pt)

4) a) $P = NE \Rightarrow N = \frac{3978 \times 10^{-4}}{39.78 \times 10^{-20}} = 10^{18}$ photons received /s. (½ pt)

b) Quantum efficiency = $\frac{n}{N} = \frac{10^{16}}{10^{18}} = 0.01 = 1\%$. (½ pt)

C – According to the wave theory, the wave gives energy to the illuminated surface progressively and continuously. This means that whatever the frequency of the incident radiation, a continuous illumination of the metal should produce photoelectric effect. (1 pt)

Fourth exercise : (6 1/2 pts)

I- 1) $E = R_1 i_1 + L \frac{di_1}{dt}$ (1/2 pt)

2) $\frac{di_1}{dt} = \frac{E}{L} e^{-\frac{R_1 t}{L}} \Rightarrow R_1 \left[\frac{E}{R_1} (1 - e^{-\frac{R_1 t}{L}}) \right] + L \left(\frac{E}{L} e^{-\frac{R_1 t}{L}} \right) = E$ [verified] (1/2 pt)

3) a) At steady state, $i_1 = \text{cte} \Rightarrow \frac{di_1}{dt} = 0$; The differential equation in this case:

$$E = R_1 I_0 + 0 \Rightarrow I_0 = \frac{E}{R_1}. \quad (3/4 \text{ pt})$$

b) $I_0 = \frac{9}{90} = 0.1 \text{ A.}$ (1/4 pt)

II-

A- 1) During the current decay, the coil, according to Lenz law, produces a current
B- in the same direction as before, from A to D in the coil (3/4 pt)

2) $u_{\text{coil}} = u_{(D2)} \Rightarrow u_{AD} = u_{AD} \Rightarrow L \frac{di_2}{dt} = -R_2 i_2 \Rightarrow L \frac{di_2}{dt} + R_2 i_2 = 0$ (1/2 pt)

3) $\frac{di_2}{dt} = -\alpha \beta e^{-\beta t} \Rightarrow -L \alpha \beta e^{-\beta t} + R_2 \alpha e^{-\beta t} = 0 \Rightarrow \alpha e^{-\beta t} (R_2 - L\beta) = 0.$

$$R_2 - L\beta = 0 \Rightarrow \beta = \frac{R_2}{L}. \quad (3/4 \text{ pt})$$

For $t = 0$, $i_2 = I_0 = \alpha = \frac{E}{R_1}$. (1/2 pt)

B – 1) Just after closing the circuit, a current I_0 passes through the lamp
 $I_0 = 0.1 \text{ A} > 0.02 \text{ A}$. Therefore the lamp illuminates. (1/2 pt)

2) $\alpha = 0.1 \text{ A}$ and $\beta = \frac{400}{1} = 400 \text{ s}^{-1} \Rightarrow i_2 = 0.1 e^{-400t}$ (1/2 pt)

$$0.02 = 0.1 e^{-400t} \Rightarrow \frac{0.02}{0.1} = e^{-400t} \Rightarrow -400t = \ln 0.2 \Rightarrow t = 4 \text{ ms} \quad (1 \text{ pt})$$