

This exam is formed of three exercises in three pages.
The use of non-programmable calculators is recommended.

First exercise: (7 points)

Harmonic oscillator

The aim of this exercise is to study the motion of a mechanical oscillator.

A – Theoretical study

For this aim, consider a small trolley (C) of mass $m = 200$ g, attached to one extremity of a horizontal spring (R); of negligible mass, and of un-jointed loops of stiffness $k = 20$ N/m; the other extremity of the spring is attached to a fixed support (A) (figure 1).

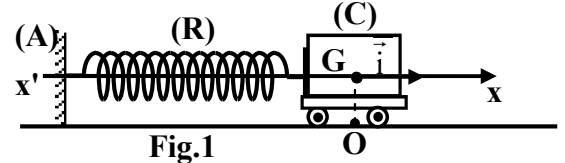

The trolley (C) may slide without friction on a horizontal rail and its center of inertia G can move along the horizontal axis $x'Ox$.

At the instant $t_0 = 0$, (G) is initially in its equilibrium position O, at this instant (C) is launched, at the instant $t_0 = 0$, with an initial velocity $\vec{V}_0 = -V_0 \vec{i}$ ($V_0 > 0$). (C) then oscillates without friction with a proper angular frequency ω_0 .

At an instant t , the abscissa of G is $x = \overline{OG}$ and the algebraic measure of its velocity is $v = \frac{dx}{dt}$.

The horizontal plane passing through G is taken as a reference level of gravitational potential energy.

- 1) Write, at an instant t , the expression of the mechanical energy of the system [(C), (R), Earth] in terms of m , k , x and v .
- 2) Derive the second order differential equation in x that describes the motion of G.
- 3) The solution of this differential equation is of the form $x = -X_m \sin(\omega_0 t)$, where X_m is a positive constant.
 - a) Determine the expression of ω_0 in terms of k and m .
 - b) Deduce the value of the proper period T_0 .
- 4) Determine the expression of the amplitude X_m in terms of V_0 , k and m .

B – Energetic study

An appropriate device allows to obtain the variations with respect to time of the kinetic energy, elastic potential energy and the mechanical energy of the system [(C), (R), Earth] (figure 2).

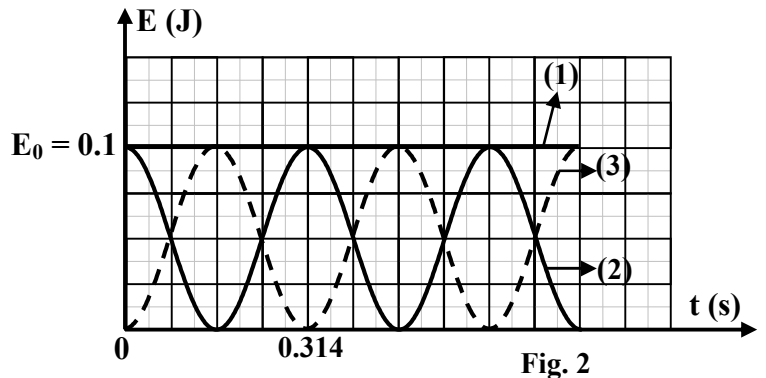

- 1) Indicate, with justification, the type of energy corresponding to each curve.
- 2) The energies represented by the curves (2) and (3) are periodic of period T .
 - a) Pick up from figure 2 the value of T .
 - b) Deduce the relation between T and T_0 .
- 3) Write the expression of E_0 in terms of m and V_0 .
- 4) Deduce the value of V_0 .

Second exercise: (7 points)

Determination of the characteristics of an electric component

An electric component (D), of unknown nature, which may be a resistor of resistance R or a pure coil of inductance L or a capacitor of capacitance C.

To determine the nature and the characteristic of (D) we consider the following:

- An ideal generator G of constant electromotive force (e.m.f) E;
- Two resistors of resistances $R_1 = 100 \Omega$ and $R_2 = 150 \Omega$;
- A double switch K.

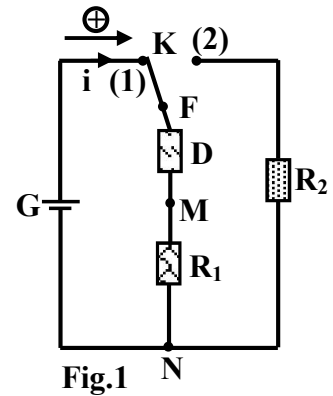

We set up the circuit of figure 1.

A – First Experiment

At an instant $t_0 = 0$, the switch K is turned to position (1). Figure 2 shows the variation of the voltage u_{FM} across the terminals of (D) as a function of time and the tangent to this curve at $t_0 = 0$.

- 1) The component (D) is a capacitor. Justify.
- 2) Indicate the value of the e.m.f E of the generator.
- 3) Calculate, at $t_0 = 0$, the current carried by the circuit.
- 4) Derive the differential equation describing the variation of the voltage $u_{FM} = u_C$.
- 5) The solution of the differential equation has the form:

$$u_C = u_{FM} = A + B e^{-\frac{t}{\tau}}$$

Determine the expressions of the constants A, B and τ in terms of R_1 , C and E.

- 6) Determine, graphically, the value of the time constant τ .
- 7) Deduce the value of C.

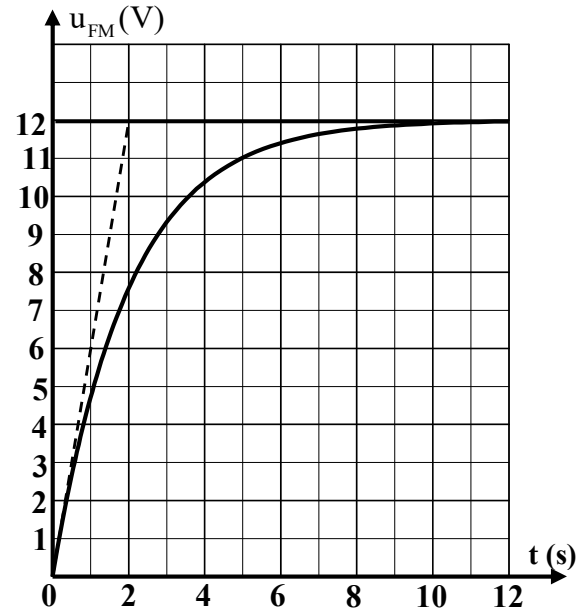

Fig. 2

B – Second Experiment.

During the charging of the capacitor and at an instant t_1 , we turn the switch K to the position (2) (figure 3).

- 1) Name the phenomenon that takes place.
- 2) The resistor R_2 can support a maximum power of $P_{max} = 0.24 \text{ W}$.
 - a) Calculate the maximum value of the current which can pass through R_2 without damaging it (the thermal power is given by the relation: $p = R i^2$).
 - b) Applying the law of addition of voltages, show that the maximum voltage across the terminals of the capacitor is $u_{FM} = 10 \text{ V}$ so that R_2 will not be damaged.
 - c) At the instant t_1 the current is maximum. Determine, graphically, the maximum duration $\Delta t = t_1$ of the charging process of the capacitor so that the resistor R_2 will not be damaged.

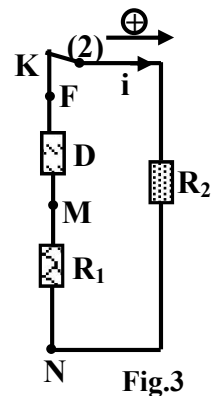

Fig.3

Third exercise: (6 points)

The radioactivity of cobalt-60

The cobalt isotope ${}^{60}_{27}\text{Co}$ is radioactive of a radioactive constant $\lambda = 4.146 \times 10^{-9} \text{ s}^{-1}$. Consider a sample of this isotope of mass $m_0 = 1 \text{ g}$ at the instant $t_0 = 0$.

Given:

Symbol	${}^{60}_{27}\text{Co}$	${}^{60}_{28}\text{Ni}$	${}^A_Z\text{X}$
Mass (in u)	59.9190	59.9154	0.00055

- $1 \text{ u} = 931.5 \text{ MeV}/c^2$;
 - Avogadro's number: $6.02 \times 10^{23} \text{ mol}^{-1}$;
 - Molar mass of cobalt: $60 \text{ g}\cdot\text{mol}^{-1}$;
 - 1 year = 365 days.
- 1) Calculate, in years, the period of the cobalt- 60 nucleus.
 - 2) a) Determine, at $t_0 = 0$, the number of nuclei N_0 presented in 1 g of cobalt- 60.
b) Define the activity A of a radioactive sample.
c) Determine the activity of the cobalt sample at the instant $t = 15.9$ years.
 - 3) The disintegrations of ${}^{60}_{27}\text{Co}$ gives rise to a nickel isotope ${}^{60}_{28}\text{Ni}$ according to the following reaction:
$${}^{60}_{27}\text{Co} \rightarrow {}^{60}_{28}\text{Ni} + {}^A_Z\text{X} + \dots\dots$$
 - a) Calculate, specifying the laws used, A and Z.
 - b) Name the emitted particles.
 - c) Calculate, in MeV, the energy liberated by this disintegration.
 - d) Determine the energy liberated by the disintegration of 1g of cobalt- 60.
 - 4) Knowing that the energy liberated by the fission of 1 g of ${}^{235}_{92}\text{U}$ is $5.127 \times 10^{23} \text{ Mev}$, calculate the mass of ${}^{235}_{92}\text{U}$ whose fission provides an energy equivalent to that liberated by the disintegration of 1 g of cobalt-60.

	امتحانات الشهادة الثانوية العامة الفرع : علوم الحياة	وزارة التربية والتعليم العالي المديرية العامة للتربية دائرة الامتحانات
الاسم: الرقم:	مسابقة في مادة الفيزياء المدة ساعتان	مشروع معيار التصحيح

First exercise : Harmonic oscillator		7
A.1	Mecahnical energy : $ME = PE_{el} + KE \Rightarrow ME = \frac{1}{2}k \cdot x^2 + \frac{1}{2}m \cdot v^2$	1/2
A.2	No friction \Rightarrow mechanical energy is conserved $\Rightarrow ME = \text{constant}$. Derive both sides with respect to time $\Rightarrow \frac{dME}{dt} = k x x' + m v v' = 0 \Rightarrow x'' + \frac{k}{m} x = 0$.	3/4
A.3.a	$x = -X_m \sin(\omega_0 t)$; $x' = -X_m \omega_0 \cos(\omega_0 t)$ and $x'' = X_m \omega_0^2 \sin(\omega_0 t)$ Replace in the differential equation: $X_m \omega_0^2 \sin(\omega_0 t) - \frac{k}{m} X_m \sin(\omega_0 t) = 0 \Rightarrow X_m \sin(\omega_0 t) (\omega_0^2 - \frac{k}{m}) = 0 \Rightarrow \omega_0 = \sqrt{\frac{k}{m}}$.	1
A.3.b	$T_0 = \frac{2\pi}{\omega_0} = 2\pi \sqrt{\frac{m}{K}} = 0.2\pi = 0.628s$	3/4
A.4	$x' = -X_m \omega_0 \cos(\omega_0 t)$; at $t_0 = 0$: $x = 0$ and $v = -X_m \omega_0 = -V_0$ $\Rightarrow X_m = \frac{V_0}{\omega_0} = V_0 \sqrt{\frac{m}{k}}$. OR : Mecahnical energy is conserved $\Rightarrow \frac{1}{2}kX_m^2 = \frac{1}{2}mV_0^2 \Rightarrow X_m = V_0 \sqrt{\frac{m}{k}}$	3/4
B.1	Curve (1) : Mechanical energy, because $ME = E_0 = \text{constant}$; Curve (2) : Kinetic energy because at $t = 0$: $v = -V_0$ and $KE = \frac{1}{2}mV_0^2 \Rightarrow E = E_0 = KE_{\max}$ Curve (3) : elastic potential energy because at $t = 0$, $x = 0 \Rightarrow PE_{el} = 0$	1 1/2
B.2.a	$T = 0.314s$	1/4
B.2.b	$T_0 = 2T$	1/2
B.3	$E_0 = KE_0 + PE_{el} = \frac{1}{2}mV_0^2 + 0 = \frac{1}{2}mV_0^2$	1/2
B.4	$0.1 = \frac{1}{2} \times 0.2 \times V_0^2 \Rightarrow V_0 = 1 \text{ m/s}$	1/2

Second exercise : Identification and determination the characteristic of an electric component		7
A.1	D is a capacitor since its voltage increases exponentially from zero to a constant limiting value.	1/2
A.2	At the end of charging, the voltage across C is E thus: $E = 12V$	1/2
A.3	At $t = 0$ s, the current is maximum, $i = I_0 \Rightarrow E = u_c + R_1 i$; $u_c = 0$ $\Rightarrow i = I_0 = \frac{E}{R_1} = \frac{12}{100} = 0.12$ A.	1
A.4	$u_{FN} = u_{FM} + u_{MN}$: $E = u_{FM} + R_1 \cdot i$ But $i = \frac{dq}{dt} = C \frac{du_{LM}}{dt}$ $\Rightarrow E = u_c + R_1 C \frac{du_c}{dt} \Rightarrow \frac{du_c}{dt} + \frac{1}{R_1 C} u_c = \frac{E}{R_1 C}$	1 1/2
A.5	$u_c = A + B e^{-\frac{t}{\tau}}$. at $t = 0 \Rightarrow 0 = A + B \Rightarrow A = -B$ $\frac{du_c}{dt} = -\frac{B}{\tau} e^{-\frac{t}{\tau}} \Rightarrow -\frac{B}{\tau} e^{-\frac{t}{\tau}} + \frac{A}{R_1 C} + \frac{B}{R_1 C} e^{-\frac{t}{\tau}} = \frac{E}{R_1 C}$ By identification $A = E$ and $\tau = R_1 C$; $B = -A = -E$	1/2
A.6	Using the graph, we get : $\tau = 2$ s ; the tangent at $t=0$, cuts the E-axis at $t = 2ms$	1/2
A.7	$\tau = R_1 C \Rightarrow C = \frac{2}{100} = 0.02F = 20$ mF.	1/2
B.1	Discharging of the capacitor	1/4
B.2.a	$P_{max} = 0.24$ W = $R_2 [I_{max}]^2 \Rightarrow I_{max} = 0.04$ A	1/2
B.2.b	$u_{FM} = u_{FN} + u_{NM} \Rightarrow u_{FM} = R_2 i + R_1 i = (R_2 + R_1) i \Rightarrow (u_{FM})_{max} = (R_2 + R_1) I_{max} = 10$ V	1/2
B.2.c	From the graph $u_c = 10V \Rightarrow t_1 = 0.35s$.	1/4

Third exercise : The radioactivity of cobalt-60		6
1	$\lambda = \frac{\ln}{T} \Rightarrow T = \frac{0.693}{4.146 \times 10^{-9} \times 365 \times 24 \times 3600} = 5.3 \text{ years}$	$\frac{3}{4}$
2.a	$N_0 = \frac{m_0}{M} \times 6.02 \times 10^{23} = 1.00333 \times 10^{22} \text{ nuclei} \approx 1 \times 10^{22} \text{ nuclei}$	$\frac{3}{4}$
2.b	The radioactive activity is the number of disintegrations per unit time.	$\frac{1}{2}$
2.c	$A = \lambda N$ with $N = N_0 e^{-\lambda t}$; $t = 3 T \Rightarrow N = 1.25 \times 10^{21} \text{ nuclei}$ $A = \lambda N = 5.2 \times 10^{12} \text{ Bq}$	1
3.a	${}^{60}_{27}\text{Co} \longrightarrow {}^{60}_{28}\text{Ni} + {}^A_Z\text{X} + \gamma + {}^0_0\bar{\nu}$ Conservation of charge number: $27 = 28 + Z, \Rightarrow Z = -1$. Conservation of mass number: $60 = 60 + A \Rightarrow A = 0$.	$\frac{3}{4}$
3.b	The emitted particles: electron and antineutrino	$\frac{1}{2}$
3.c	$\Delta m = m_{\text{before}} - m_{\text{after}} = (59.9190) - (59.9154 + 0.00055) = 3.05 \times 10^{-3} \text{ u}$ $E_\ell = \Delta m c^2 = 3.05 \times 10^{-3} \times 931.5 = 2.84 \text{ MeV}$	$\frac{3}{4}$
3.d	Energy liberated by 1 g de Co: $E' = N_0 E_\ell = 2.84 \times 10^{22} \text{ MeV}$	$\frac{1}{2}$
4	$m_U = \frac{2.84 \times 10^{22}}{5.127 \times 10^{23}} = 0.055 \text{ g}$	$\frac{1}{2}$